

GENERAL CHARACTERISTICS



The indicators of flow of CV series allow a visual inspection of the passage of liquids in hydraulic systems. The propeller is coloured for better visualization with opaque liquids. The indicator is equipped with a viewer pipe in natural glass.

- Rugged construction.
- Bidirectional operation.
- Viewer pipe made in high resistance glass.
- Easy to install.



TECHNICAL DATA

Tab.1

Ø	DN Code	Q max. l/min	Q min. to start the rotor l/min			ΔP max Bar	P max Bar	T max °C	Weight Kg	Dimensions mm			
			H ₂ O	40 cSt	41-150 cSt					A	B	C	SW
1/4"	008	10	0,6	2,5	3,5	0,15	25	100	0,1	66	22	44	20
3/8"	010	20	1,2	3	4	0,25	15	100	0,17	92	36	60	28
1/2"	015	40	1,2	3	4	0,3	15	100	0,17	92	36	60	28
3/4"	020	60	2,1	3,7	5	0,17	12	100	0,7	114	46	70	46
1"	025	80	2,1	3,7	5	0,15	12	100	0,6	114	46	70	46
On request		Only with body and connections in: Nickel plated brass BB or anodized aluminium DD											
1.1/4"	032	120	3,5	5,5	7	0,1	10	100	2,9	165	66	94	60
1.1/2"	040	160	3,5	5,5	7	0,1	10	100	2,9	165	66	94	60
2"	050	190	7	----	----	0,1	10	100	3	165	66	94	70
													See Tab.3

Thread Ø

G	UNI 228/1	N	NPT
	Parallel		Conical on request

MATERIALS

Tab.2

Description	Code			
	PSO	PSK	BB	DD
DN	008 ÷ 025	008 ÷ 025	032 ÷ 050	032 ÷ 050
Body	Latene	Latene	Brass (*)	Aluminium
Fittings	Brass	AISI-316	Brass (*)	Aluminium
Rotor	R PP- red	PP- red	PP- red	PP- red
	B PP- blue	PP- blue	PP- blue	PP- blue
Axes	PP	PP	PP	PP
Viewer pipe	Pyrex glass	Pyrex glass	Pyrex glass	Pyrex glass
Gasket	NBR	Viton	NBR	NBR

(*) Nickel plated brass

INSTALLATION

The mounting can take place in any position, with the only precaution to avoid the connection with rigid pipes if not in perfect alignment with the instrument.

DIMENSIONS

Tab.3

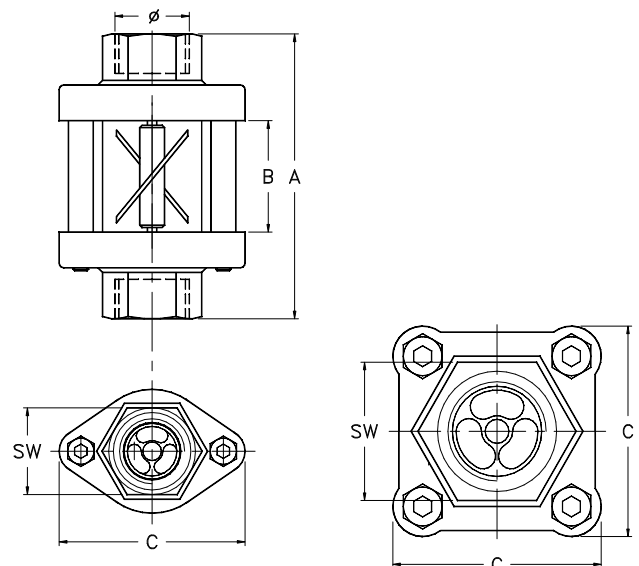

NOMENCLATURE

CV	025G	PSO	R
•			
	•		
		•	
			•

	Name - Type
Tab.1	Process connection dimensions
Tab.2	Body material - Fittings
Tab.2	Colour of the propeller